

SECTION **IP**
INSTRUMENT PANEL

A
B
C
D
E
F
G
H
I
IP
K
L
M
N
O
P

CONTENTS

PRECAUTION	2	CLUSTER LID C FINISHER	16
PRECAUTIONS	2	CLUSTER LID C FINISHER : Removal and Instal-	
Precaution for Supplemental Restraint System		lation	16
(SRS) "AIR BAG" and "SEAT BELT PRE-TEN-		CLUSTER LID C LOWER	16
SIONER"	2	CLUSTER LID C LOWER : Removal and Installa-	
Precaution for Work	2	tion	17
PREPARATION	3	INSTRUMENT UPPER PANEL	17
PREPARATION	3	INSTRUMENT UPPER PANEL : Removal and In-	
Special Service Tool	3	stallation	17
Commercial Service Tool	3	STEERING COLUMN COVERS	18
CLIP LIST	4	Removal and Installation	18
Descriptions for Clips	4	CLUSTER LID A	19
SYMPTOM DIAGNOSIS	8	Removal and Installation	19
SQUEAK AND RATTLE TROUBLE DIAG-		CLUSTER LID C	20
NOSES	8	Removal and Installation	20
Work Flow	8	GLOVE BOX ASSEMBLY AND HOUSING	21
Generic Squeak and Rattle Troubleshooting	9	Removal and Installation	21
Diagnostic Worksheet	12	INSTRUMENT LOWER PANEL LH	22
REMOVAL AND INSTALLATION	14	Removal and Installation	22
INSTRUMENT PANEL ASSEMBLY	14	CENTER CONSOLE	23
Exploded View	14	Exploded View	23
Removal and Installation	14	Removal and Installation	24
INSTRUMENT FINISHER A	15	UNIT DISASSEMBLY AND ASSEMBLY ...	25
INSTRUMENT FINISHER A : Removal and Instal-		CENTER CONSOLE ASSEMBLY	25
lation	15	Exploded View	25
INSTRUMENT FINISHER B	16	Disassembly and Assembly	26
INSTRUMENT FINISHER B : Removal and Instal-			
lation	16		

PRECAUTIONS

< PRECAUTION >

PRECAUTION

PRECAUTIONS

Precaution for Supplemental Restraint System (SRS) "AIR BAG" and "SEAT BELT PRE-TENSIONER"

INFOID:000000013481952

The Supplemental Restraint System such as "AIR BAG" and "SEAT BELT PRE-TENSIONER", used along with a front seat belt, helps to reduce the risk or severity of injury to the driver and front passenger for certain types of collision. Information necessary to service the system safely is included in the SR and SB section of this Service Manual.

WARNING:

- To avoid rendering the SRS inoperative, which could increase the risk of personal injury or death in the event of a collision which would result in air bag inflation, it is recommended that all maintenance and repair be performed by an authorized NISSAN/INFINITI dealer.
- Improper repair, including incorrect removal and installation of the SRS, can lead to personal injury caused by unintentional activation of the system. For removal of Spiral Cable and Air Bag Module, see the SR section.
- Do not use electrical test equipment on any circuit related to the SRS unless instructed to in this Service Manual. SRS wiring harnesses can be identified by yellow and/or orange harnesses or harness connectors.

PRECAUTIONS WHEN USING POWER TOOLS (AIR OR ELECTRIC) AND HAMMERS

WARNING:

- When working near the Air Bag Diagnosis Sensor Unit or other Air Bag System sensors with the Ignition ON or engine running, DO NOT use air or electric power tools or strike near the sensor(s) with a hammer. Heavy vibration could activate the sensor(s) and deploy the air bag(s), possibly causing serious injury.
- When using air or electric power tools or hammers, always switch the Ignition OFF, disconnect the battery or batteries, and wait at least three minutes before performing any service.

Precaution for Work

INFOID:000000012545581

- When removing or disassembling each component, be careful not to damage or deform it. If a component may be subject to interference, be sure to protect it with a shop cloth.
- When removing (disengaging) components with a screwdriver or similar tool, be sure to wrap the component with a shop cloth or vinyl tape to protect it.
- Protect the removed parts with a shop cloth and prevent them from being dropped.
- Replace a deformed or damaged clip.
- If a part is specified as a non-reusable part, always replace it with a new one.
- Be sure to tighten bolts and nuts securely to the specified torque.
- After installation is complete, be sure to check that each part works properly.
- Follow the steps below to clean components:
 - Water soluble dirt:
 - Dip a soft cloth into lukewarm water, wring the water out of the cloth and wipe the dirty area.
 - Then rub with a soft, dry cloth.
 - Oily dirt:
 - Dip a soft cloth into lukewarm water with mild detergent (concentration: within 2 to 3%) and wipe the dirty area.
 - Then dip a cloth into fresh water, wring the water out of the cloth and wipe the detergent off.
 - Then rub with a soft, dry cloth.
 - Do not use organic solvent such as thinner, benzene, alcohol or gasoline.
 - For genuine leather seats, use a genuine leather seat cleaner.

PREPARATION

< PREPARATION >

PREPARATION

PREPARATION

Special Service Tool

INFOID:000000012545582

The actual shape of the tools may differ from those illustrated here.

Tool number (TechMate No.) Tool name	Description
— (J-39570) Chassis Ear	Locating the noise
— (J-50397) NISSAN Squeak and Rattle kit	Repairing the cause of noise
— (J-46534) Trim Tool Set	Removing trim components

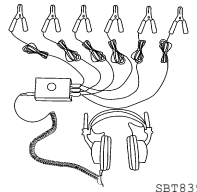

SBT839



ALJIA12322Z

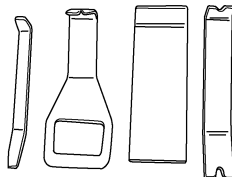

ANJIA04832Z

Commercial Service Tool

INFOID:000000012545583

(TechMate No.) Tool name	Description
(J-39565) Engine Ear	Locating the noise
(—) Power Tool	Loosening nuts, screws and bolts

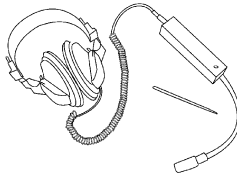

SIIA0995E



PIIB1407E

CLIP LIST







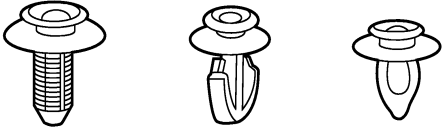

< PREPARATION >

CLIP LIST

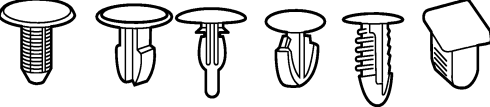
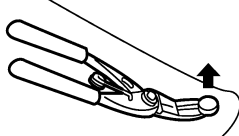
Descriptions for Clips

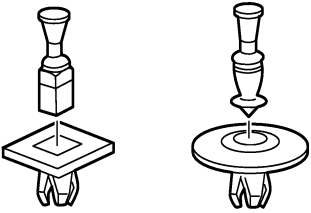
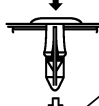
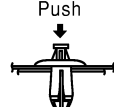
INFOID:000000013111597

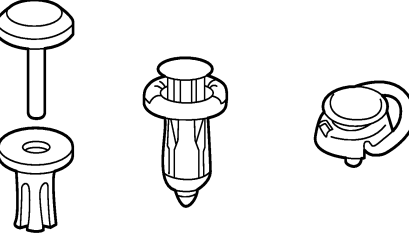
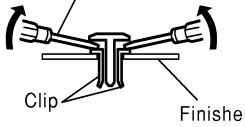

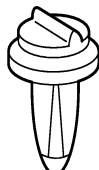
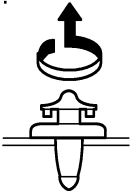





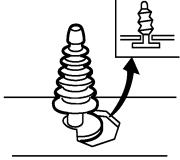
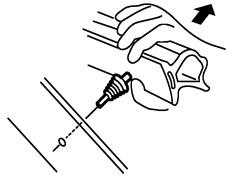

Replace any clips which are damaged during removal or installation.

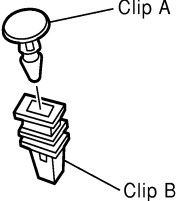
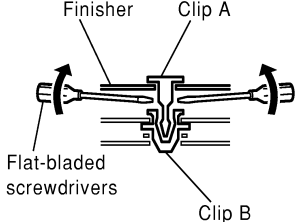
Symbol No.	Shapes	Removal & Installation
<p>C101</p> 		<p>Removal: Remove by bending up with flat-bladed screwdrivers or clip remover.</p> 
<p>C103</p> 		 <p>Removal: Remove with a clip remover.</p>
<p>C203</p> 		<p>Removal: Push center pin to catching position. (Do not remove center pin by hitting it.)</p> <p>Push</p>  <p>Installation:</p> 
<p>C205</p> 		<p>Removal:</p>  <p>Flat-bladed screwdriver</p> <p>Clip</p> <p>Finisher</p>
<p>C206</p> 		<p>Removal:</p> 

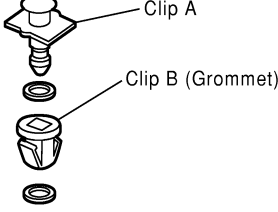
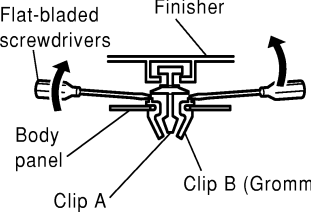
S1IA0315E

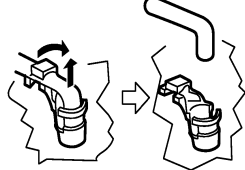
CLIP LIST

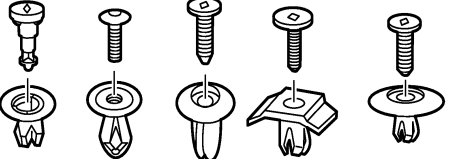
< PREPARATION >









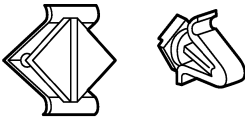

Symbol No.	Shapes	Removal & Installation
<p>CE103</p> 		<p>Removal:</p> 
<p>CF110</p> 		<p>Removal:</p> 
<p>CF118</p> 		<p>Removal:</p> 
<p>CR103</p> 		<p>Removal: Holder portion of clip must be spread out to remove rod.</p> 
<p>CS101</p> 		<p>Removal:</p> <ol style="list-style-type: none"> 1. Screw out with a Phillips screwdriver. 2. Remove female portion with flat-bladed screwdriver. 

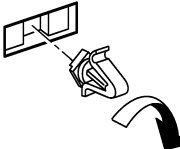
SIIA0316E

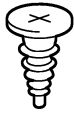
A
B
C
D
E
F
G
H
I
IP
K
L
M
N
O
P

CLIP LIST

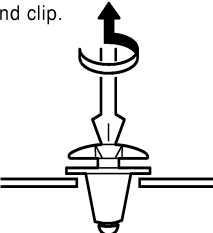

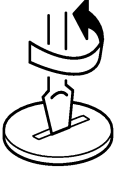
< PREPARATION >

Symbol No.	Shapes	Removal & Installation	
CG101 		Removal:  Rotate 45° to remove	Installation: 
CS102 			
CS113 		Removal: Disconnect upper connection of clip with a flat-bladed screwdriver, then remove clip while inserting a flat-bladed screwdriver between body panel and clip. 	
C111 			

SIIA0317E

CLIP LIST

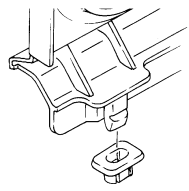
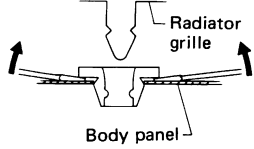
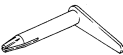
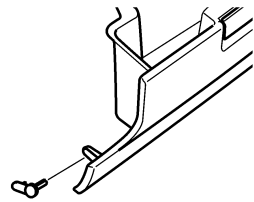
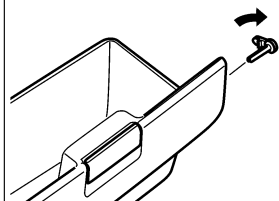
< PREPARATION >

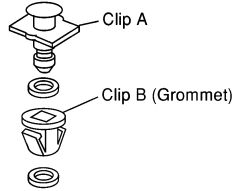
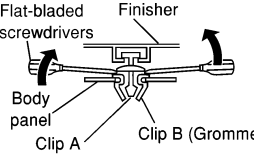
Symbol No.	Shapes	Removal & Installation
<p>CG104</p> 		<p>Removal: Remove by bending up with flat-bladed screwdrivers.</p> 
<p>CE114</p> 		
<p>CF118</p> 		<p>Removal: Flat-bladed screwdrivers Finisher</p> 

ALJIA0564GB

A
B
C
D
E
F
G
H
I
IP
K
L
M
N
O
P

SQUEAK AND RATTLE TROUBLE DIAGNOSES

< SYMPTOM DIAGNOSIS >

SYMPTOM DIAGNOSIS

SQUEAK AND RATTLE TROUBLE DIAGNOSES

Work Flow

INFOID:000000012545584

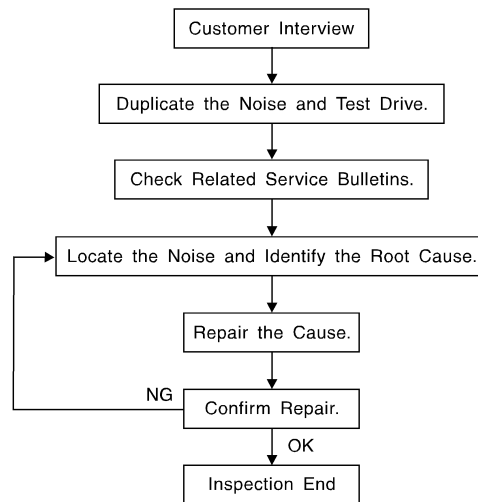

SBT842

CUSTOMER INTERVIEW

Interview the customer if possible, to determine the conditions that exist when the noise occurs. Use the Diagnostic Worksheet during the interview to document the facts and conditions when the noise occurs and any customer's comments; refer to [IP-12, "Diagnostic Worksheet"](#). This information is necessary to duplicate the conditions that exist when the noise occurs.

- The customer may not be able to provide a detailed description or the location of the noise. Attempt to obtain all the facts and conditions that exist when the noise occurs (or does not occur).
- If there is more than one noise in the vehicle, be sure to diagnose and repair the noise that the customer is concerned about. This can be accomplished by test driving the vehicle with the customer.
- After identifying the type of noise, isolate the noise in terms of its characteristics. The noise characteristics are provided so the customer, service adviser and technician are all speaking the same language when defining the noise.
- Squeak —(Like tennis shoes on a clean floor)
Squeak characteristics include the light contact/fast movement/brought on by road conditions/hard surfaces = higher pitch noise/softer surfaces = lower pitch noises/edge to surface = chirping.
- Creak—(Like walking on an old wooden floor)
Creak characteristics include firm contact/slow movement/twisting with a rotational movement/pitch dependent on materials/often brought on by activity.
- Rattle—(Like shaking a baby rattle)
Rattle characteristics include the fast repeated contact/vibration or similar movement/loose parts/missing clip or fastener/incorrect clearance.
- Knock —(Like a knock on a door)
Knock characteristics include hollow sounding/sometimes repeating/often brought on by driver action.
- Tick—(Like a clock second hand)
Tick characteristics include gentle contacting of light materials/loose components/can be caused by driver action or road conditions.
- Thump—(Heavy, muffled knock noise)
Thump characteristics include softer knock/dead sound often brought on by activity.
- Buzz—(Like a bumble bee)
Buzz characteristics include high frequency rattle/firm contact.
- Often the degree of acceptable noise level will vary depending upon the person. A noise that you may judge as acceptable may be very irritating to the customer.
- Weather conditions, especially humidity and temperature, may have a great effect on noise level.

DUPLICATE THE NOISE AND TEST DRIVE

SQUEAK AND RATTLE TROUBLE DIAGNOSES

< SYMPTOM DIAGNOSIS >

If possible, drive the vehicle with the customer until the noise is duplicated. Note any additional information on the Diagnostic Worksheet regarding the conditions or location of the noise. This information can be used to duplicate the same conditions when you confirm the repair.

If the noise can be duplicated easily during the test drive, to help identify the source of the noise, try to duplicate the noise with the vehicle stopped by doing one or all of the following:

- 1) Close a door.
 - 2) Tap or push/pull around the area where the noise appears to be coming from.
 - 3) Rev the engine.
 - 4) Use a floor jack to recreate vehicle "twist".
 - 5) At idle, apply engine load (electrical load, half-clutch on M/T model, drive position on CVT and A/T models).
 - 6) Raise the vehicle on a hoist and hit a tire with a rubber hammer.
- Drive the vehicle and attempt to duplicate the conditions the customer states exist when the noise occurs.
 - If it is difficult to duplicate the noise, drive the vehicle slowly on an undulating or rough road to stress the vehicle body.

CHECK RELATED SERVICE BULLETINS

After verifying the customer concern or symptom, check ASIST for Technical Service Bulletins (TSBs) related to that concern or symptom.

If a TSB relates to the symptom, follow the procedure to repair the noise.

LOCATE THE NOISE AND IDENTIFY THE ROOT CAUSE

1. Narrow down the noise to a general area. To help pinpoint the source of the noise, use a listening tool (Chassis Ear: J-39570, Engine Ear: J-39565 and mechanic's stethoscope).
2. Narrow down the noise to a more specific area and identify the cause of the noise by:
 - removing the components in the area that you suspect the noise is coming from.
Do not use too much force when removing clips and fasteners, otherwise clips and fasteners can be broken or lost during the repair, resulting in the creation of new noise.
 - tapping or pushing/pulling the component that you suspect is causing the noise.
Do not tap or push/pull the component with excessive force, otherwise the noise will be eliminated only temporarily.
 - feeling for a vibration with your hand by touching the component(s) that you suspect is (are) causing the noise.
 - placing a piece of paper between components that you suspect are causing the noise.
 - looking for loose components and contact marks.Refer to [IP-9, "Generic Squeak and Rattle Troubleshooting"](#).

REPAIR THE CAUSE

- If the cause is a loose component, tighten the component securely.
- If the cause is insufficient clearance between components:
 - separate components by repositioning or loosening and retightening the component, if possible.
 - insulate components with a suitable insulator such as urethane pads, foam blocks, felt cloth tape or urethane tape. A NISSAN Squeak and Rattle Kit (J-50397) is available through your authorized NISSAN Parts Department.

CAUTION:

Do not use excessive force as many components are constructed of plastic and may be damaged.

NOTE:

- Always check with the Parts Department for the latest parts information.
- The materials contained in the NISSAN Squeak and Rattle Kit (J-50397) are listed on the inside cover of the kit; and can each be ordered separately as needed.
- The following materials not found in the kit can also be used to repair squeaks and rattles.
 - SILICONE GREASE: Use instead of UHMW tape that will be visible or does not fit. The silicone grease will only last a few months.
 - SILICONE SPRAY: Use when grease cannot be applied.
 - DUCT TAPE: Use to eliminate movement.

CONFIRM THE REPAIR

Confirm that the cause of a noise is repaired by test driving the vehicle. Operate the vehicle under the same conditions as when the noise originally occurred. Refer to the notes on the Diagnostic Worksheet.

Generic Squeak and Rattle Troubleshooting

INFOID:000000012545585

Refer to Table of Contents for specific component removal and installation information.

SQUEAK AND RATTLE TROUBLE DIAGNOSES

< SYMPTOM DIAGNOSIS >

INSTRUMENT PANEL

Most incidents are caused by contact and movement between:

1. Cluster lid A and the instrument panel
2. Acrylic lens and combination meter housing
3. Instrument panel to front pillar finisher
4. Instrument panel to windshield
5. Instrument panel pins
6. Wiring harnesses behind the combination meter
7. A/C defroster duct and duct joint

These incidents can usually be located by tapping or moving the components to duplicate the noise or by pressing on the components while driving to stop the noise. Most of these incidents can be repaired by applying felt cloth tape or silicone spray (in hard to reach areas). Urethane pads can be used to insulate wiring harness.

CAUTION:

Do not use silicone spray to isolate a squeak or rattle. If you saturate the area with silicone, you will not be able to recheck the repair.

CENTER CONSOLE

Components to pay attention to include:

1. Shift selector assembly cover to finisher
2. A/C control unit and cluster lid C
3. Wiring harnesses behind audio and A/C control unit

The instrument panel repair and isolation procedures also apply to the center console.

DOORS

Pay attention to the:

1. Finisher and inner panel making a slapping noise
2. Inside handle escutcheon to door finisher
3. Wiring harnesses tapping
4. Door striker out of alignment causing a popping noise on starts and stops

Tapping or moving the components or pressing on them while driving to duplicate the conditions can isolate many of these incidents. You can usually insulate the areas with felt cloth tape or insulator foam blocks from the NISSAN Squeak and Rattle Kit (J-50397) to repair the noise.

TRUNK

Trunk noises are often caused by a loose jack or loose items put into the trunk by the owner.

In addition look for:

1. Trunk lid bumpers out of adjustment
2. Trunk lid striker out of adjustment
3. The trunk lid torsion bars knocking together
4. A loose license plate or bracket

Most of these incidents can be repaired by adjusting, securing or insulating the item(s) or component(s) causing the noise.

SUNROOF/HEADLINING

Noises in the sunroof/headlining area can often be traced to one of the following:

1. Sunroof lid, rail, linkage or seals making a rattle or light knocking noise
2. Sun visor shaft shaking in the holder
3. Front or rear windshield touching headlining and squeaking

Again, pressing on the components to stop the noise while duplicating the conditions can isolate most of these incidents. Repairs usually consist of insulating with felt cloth tape.

OVERHEAD CONSOLE (FRONT AND REAR)

Overhead console noises are often caused by the console panel clips not being engaged correctly. Most of these incidents are repaired by pushing up on the console at the clip locations until the clips engage.

In addition look for:

SQUEAK AND RATTLE TROUBLE DIAGNOSES

< SYMPTOM DIAGNOSIS >

1. Loose harness or harness connectors.
2. Front console map/reading lamp lens loose.
3. Loose screws at console attachment points.

A

SEATS

When isolating seat noise it's important to note the position the seat is in and the load placed on the seat when the noise is present. These conditions should be duplicated when verifying and isolating the cause of the noise.

B

Cause of seat noise include:

C

1. Headrest rods and holder
2. A squeak between the seat pad cushion and frame
3. The rear seatback lock and bracket

D

These noises can be isolated by moving or pressing on the suspected components while duplicating the conditions under which the noise occurs. Most of these incidents can be repaired by repositioning the component or applying urethane tape to the contact area.

E

UNDERHOOD

Some interior noise may be caused by components under the hood or on the engine wall. The noise is then transmitted into the passenger compartment.

F

Causes of transmitted underhood noise include:

1. Any component installed to the engine wall
2. Components that pass through the engine wall
3. Engine wall mounts and connectors
4. Loose radiator installation pins
5. Hood bumpers out of adjustment
6. Hood striker out of adjustment

G

H

These noises can be difficult to isolate since they cannot be reached from the interior of the vehicle. The best method is to secure, move or insulate one component at a time and test drive the vehicle. Also, engine rpm or load can be changed to isolate the noise. Repairs can usually be made by moving, adjusting, securing, or insulating the component causing the noise.

I

IP

K

L

M

N

O

P

SQUEAK AND RATTLE TROUBLE DIAGNOSES

< SYMPTOM DIAGNOSIS >

Diagnostic Worksheet

INFOID:000000012545586

Dear Customer:

We are concerned about your satisfaction with your vehicle. Repairing a squeak or rattle sometimes can be very difficult. To help us fix your vehicle right the first time, please take a moment to note the area of the vehicle where the squeak or rattle occurs and under what conditions. You may be asked to take a test drive with a service advisor or technician to ensure we confirm the noise you are hearing.

SQUEAK & RATTLE DIAGNOSTIC WORKSHEET

I. WHERE DOES THE NOISE COME FROM? (circle the area of the vehicle)

The illustrations are for reference only, and may not reflect the actual configuration of your vehicle.

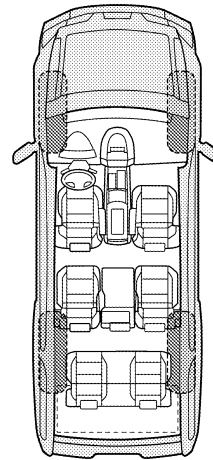
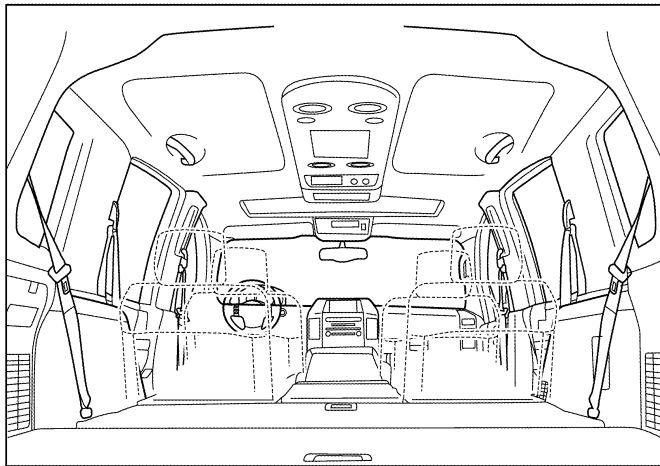
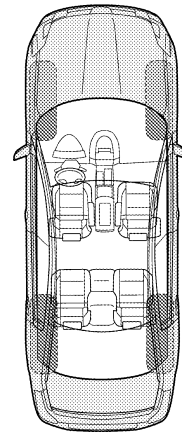
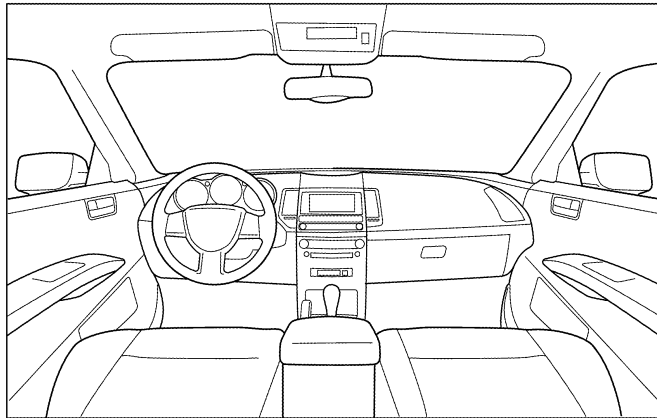

Continue to page 2 of the worksheet and briefly describe the location of the noise or rattle. In addition, please indicate the conditions which are present when the noise occurs.

SQUEAK AND RATTLE TROUBLE DIAGNOSES

< SYMPTOM DIAGNOSIS >

SQUEAK & RATTLE DIAGNOSTIC WORKSHEET - page 2

Briefly describe the location where the noise occurs:

II. WHEN DOES IT OCCUR? (please check the boxes that apply)

- | | |
|---|--|
| <input type="checkbox"/> Anytime | <input type="checkbox"/> After sitting out in the rain |
| <input type="checkbox"/> 1st time in the morning | <input type="checkbox"/> When it is raining or wet |
| <input type="checkbox"/> Only when it is cold outside | <input type="checkbox"/> Dry or dusty conditions |
| <input type="checkbox"/> Only when it is hot outside | <input type="checkbox"/> Other: |

III. WHEN DRIVING:

- Through driveways
- Over rough roads
- Over speed bumps
- Only about ____ mph
- On acceleration
- Coming to a stop
- On turns: left, right or either (circle)
- With passengers or cargo
- Other: _____
- After driving ____ miles or ____ minutes

IV. WHAT TYPE OF NOISE

- Squeak (like tennis shoes on a clean floor)
- Creak (like walking on an old wooden floor)
- Rattle (like shaking a baby rattle)
- Knock (like a knock at the door)
- Tick (like a clock second hand)
- Thump (heavy muffled knock noise)
- Buzz (like a bumble bee)

TO BE COMPLETED BY DEALERSHIP PERSONNEL

Test Drive Notes:

	YES	NO	Initials of person performing
Vehicle test driven with customer	<input type="checkbox"/>	<input type="checkbox"/>	_____
- Noise verified on test drive	<input type="checkbox"/>	<input type="checkbox"/>	_____
- Noise source located and repaired	<input type="checkbox"/>	<input type="checkbox"/>	_____
- Follow up test drive performed to confirm repair	<input type="checkbox"/>	<input type="checkbox"/>	_____

VIN: _____ Customer Name _____

W.O.# _____ Date: _____

This form must be attached to Work Order

LATA0071E

A
B
C
D
E
F
G
H
I
IP
K
L
M
N
O
P

INSTRUMENT PANEL ASSEMBLY

< REMOVAL AND INSTALLATION >

REMOVAL AND INSTALLATION

INSTRUMENT PANEL ASSEMBLY

Exploded View

INFOID:000000012545587

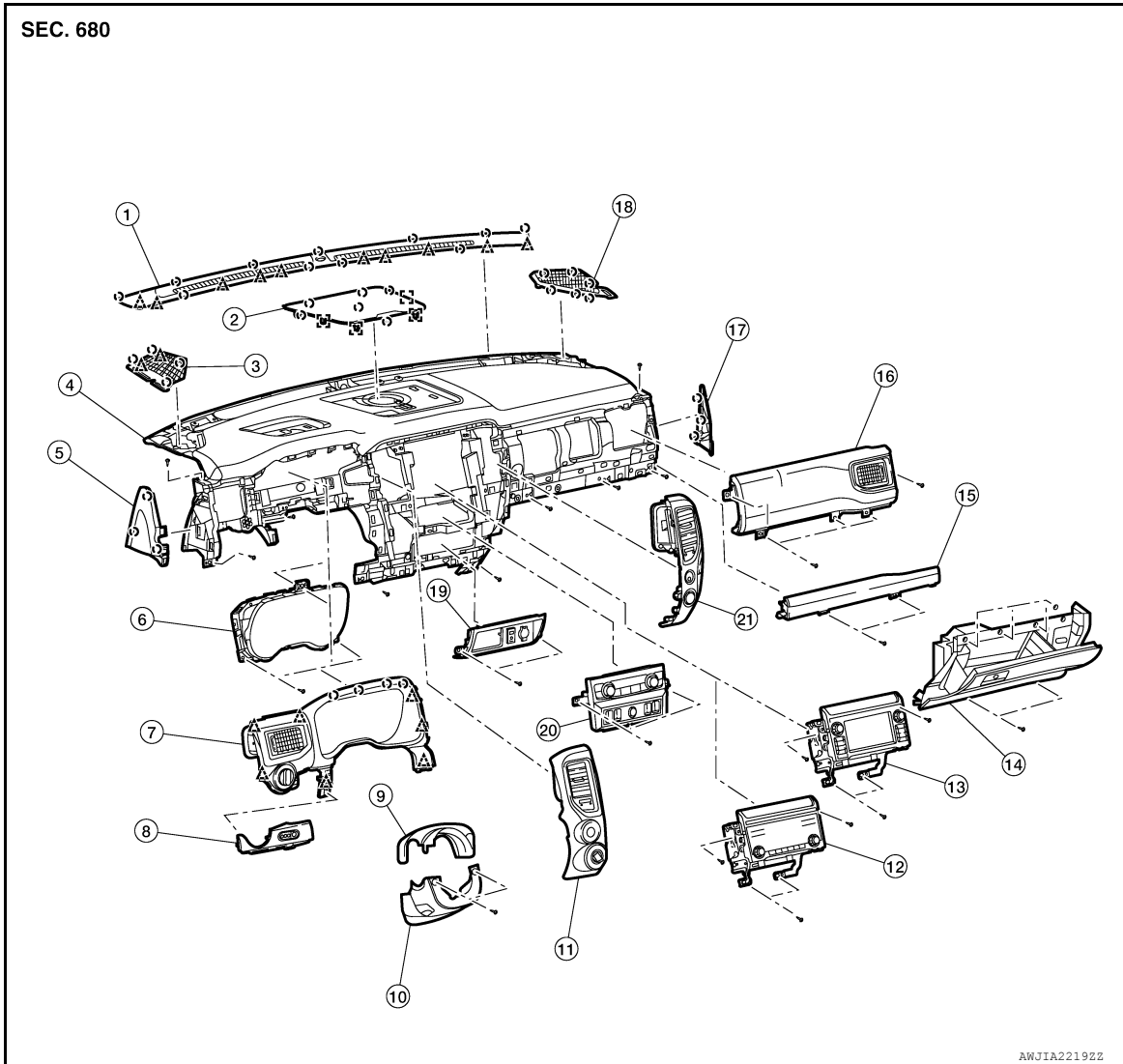

- | | | |
|-----------------------------------|------------------------------------|---------------------------------|
| 1. Front defroster grille | 2. Center speaker grille | 3. Speaker grille (LH) |
| 4. Instrument panel assembly | 5. Instrument side finisher (LH) | 6. Combination meter |
| 7. Cluster lid A | 8. Instrument finisher A | 9. Steering column upper cover |
| 10. Steering column lower cover | 11. Cluster lid C finisher (LH) | 12. Audio unit |
| 13. AV control unit (if equipped) | 14. Glove box assembly and housing | 15. Instrument finisher B |
| 16. Upper instrument panel | 17. Instrument side finisher (RH) | 18. Speaker grille (RH) |
| 19. Cluster lid C lower | 20. Cluster lid C | 21. Cluster lid C finisher (RH) |

Removal and Installation

INFOID:000000012545588

CAUTION:

- Be careful not to scratch instrument panel pad and other parts.
- Before servicing, turn ignition switch OFF, disconnect both batteries and wait at least three minutes.
- Be careful not to damage parts while removing center console assembly.

INSTRUMENT PANEL ASSEMBLY

< REMOVAL AND INSTALLATION >

REMOVAL

1. Disconnect both batteries, then wait at least three minutes. Refer to [PG-176, "Removal and Installation - CUMMINS 5.0L"](#).
2. Remove center console. Refer to [IP-24, "Removal and Installation"](#).
3. Remove glove box assembly and housing. Refer to [IP-21, "Removal and Installation"](#).
4. Remove steering column. Refer to [ST-37, "Removal and Installation"](#).
5. Remove instrument panel side finishers (LH/RH) using a suitable tool.
6. Remove combination meter. Refer to [MWI-108, "Removal and Installation"](#).
7. Remove cluster lid C. Refer to [IP-20, "Removal and Installation"](#).
8. Remove audio unit or AV control unit. Refer to [AV-66, "Removal and Installation"](#) (DISPLAY AUDIO), [AV-157, "Removal and Installation"](#) (NAVIGATION WITHOUT AMPLIFIER), [AV-277, "Removal and Installation"](#) (NAVIGATION WITH AMPLIFIER), [AV-359, "Removal and Installation"](#) (AROUND VIEW MONITOR SYSTEM), [AV-438, "Removal and Installation"](#) (TELEMATICS SYSTEM), or [AV-461, "Removal and Installation"](#) [REAR SEAT ENTERTAINMENT (RSE) SYSTEM].
9. Partially remove body side welt (LH/RH). Refer to [INT-22, "BODY SIDE WELT : Removal and Installation"](#).
10. Remove front pillar finisher (LH/RH). Refer to [INT-20, "FRONT PILLAR FINISHER : Removal and Installation"](#).
11. Remove sunload sensor. Refer to [HAC-121, "Removal and Installation"](#).
12. Remove front defroster grille using a suitable tool.
13. Remove center speaker grille and speaker grilles (LH/RH) using a suitable tool.
14. Remove instrument upper panel. Refer to [IP-17, "INSTRUMENT UPPER PANEL : Removal and Installation"](#).
15. Remove front passenger air bag module bolts. Refer to [SR-17, "Removal and Installation"](#).
CAUTION:
Do not reuse the front passenger air bag module bolts.
16. Remove instrument panel screws.
17. Disconnect harness connectors from instrument panel assembly and front passenger air bag module.
18. Remove instrument panel assembly.

INSTALLATION

Installation is in the reverse order of removal.

- If replacing instrument panel, transfer all necessary parts to the new instrument panel.

CAUTION:

- **Do not reuse the front passenger air bag module bolts.**
- **Do not damage the front passenger air bag module harnesses during installation.**
- **Tighten front passenger air bag bolts to specification. Refer to [SR-17, "Exploded View"](#).**
- **After installation is complete, check that no system malfunction is detected causing the air bag warning lamp to illuminate.**
- **If a malfunction is indicated by the air bag warning lamp after repair or replacement of the malfunctioning parts, perform the SRS final check. Refer to [SRC-12, "SRS Final Check"](#).**

INSTRUMENT FINISHER A

INSTRUMENT FINISHER A : Removal and Installation

INFOID:000000012966100

REMOVAL

1. Remove instrument lower panel LH. Refer to [IP-22, "Removal and Installation"](#).

INSTRUMENT PANEL ASSEMBLY

< REMOVAL AND INSTALLATION >

2. Release instrument finisher A clips using a suitable tool, then remove instrument finisher A.

 : Clip

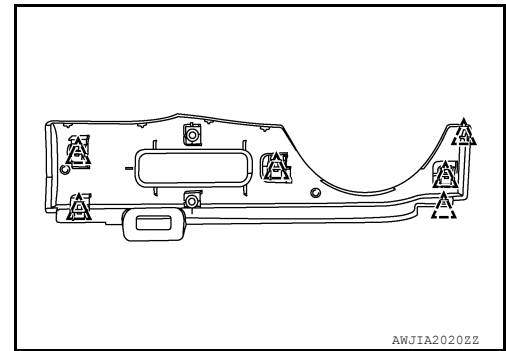

INSTALLATION

Installation is in the reverse order of removal.

INSTRUMENT FINISHER B

INSTRUMENT FINISHER B : Removal and Installation

INFOID:000000012966101

REMOVAL

1. Remove glove box assembly and housing. Refer to [IP-21, "Removal and Installation"](#).
2. Remove instrument finisher B screws (A), release instrument finisher B clips, then remove instrument finisher B (1).

 : Clip

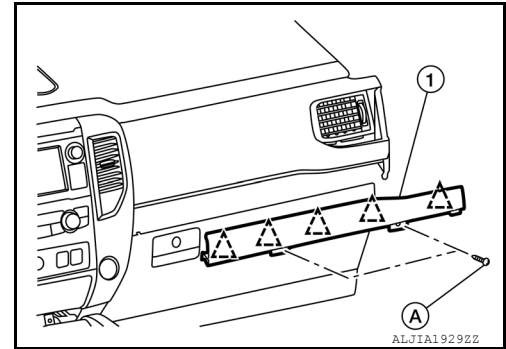

INSTALLATION

Installation is in the reverse order of removal.

CLUSTER LID C FINISHER

CLUSTER LID C FINISHER : Removal and Installation

INFOID:000000012966102

REMOVAL

NOTE:

RH side shown, LH side similar.

1. Remove center console. Refer to [IP-24, "Removal and Installation"](#).
2. Release the cluster lid C finisher clips using a suitable tool.
3. Disconnect all harness connectors and remove cluster lid C finisher.

 : Clip

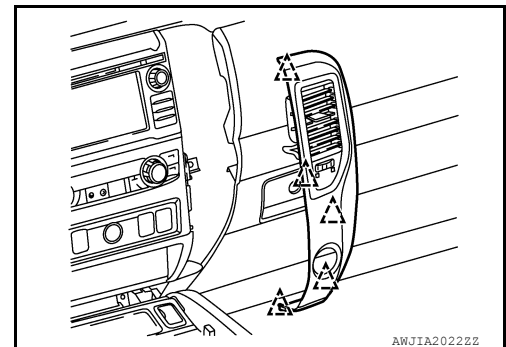

INSTALLATION

Installation is in the reverse order of removal.

CLUSTER LID C LOWER

INSTRUMENT PANEL ASSEMBLY

< REMOVAL AND INSTALLATION >

CLUSTER LID C LOWER : Removal and Installation

INFOID:000000012966103

REMOVAL

1. Remove cluster lid C finishers (LH/RH). Refer to [IP-16, "CLUSTER LID C FINISHER : Removal and Installation"](#).
2. Remove cluster lid C lower screws (A).
3. Release the clips for cluster lid C lower using a suitable tool.

 : Clip

4. Disconnect all harness connectors then remove cluster lid C lower (1).

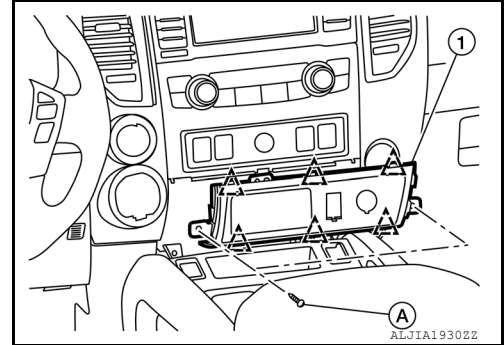

INSTALLATION

Installation is in the reverse order of removal.

INSTRUMENT UPPER PANEL

INSTRUMENT UPPER PANEL : Removal and Installation

INFOID:000000012966104

REMOVAL

1. Remove cluster lid C finishers (LH/RH). Refer to [IP-16, "CLUSTER LID C FINISHER : Removal and Installation"](#).
2. Remove instrument finisher B. Refer to [IP-16, "INSTRUMENT FINISHER B : Removal and Installation"](#).
3. Remove instrument upper panel screws (A).
4. Release instrument upper panel clips using a suitable tool, then remove instrument upper panel (1).

 : Clip

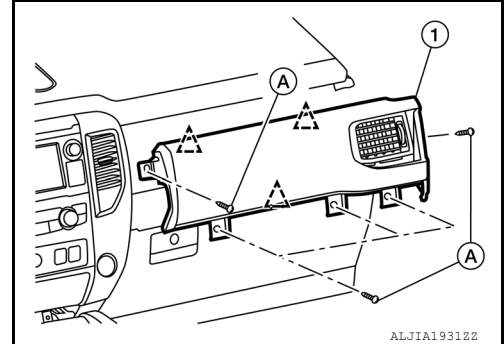

INSTALLATION

Installation is in the reverse order of removal.

STEERING COLUMN COVERS

< REMOVAL AND INSTALLATION >

STEERING COLUMN COVERS

Removal and Installation

INFOID:000000012978184

REMOVAL

1. Remove instrument lower panel LH. Refer to [IP-22. "Removal and Installation"](#).
2. Release gap hider (1) clips from the steering column upper cover (2).

 : Clip

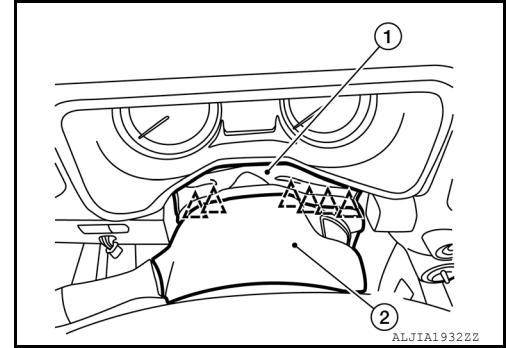

3. Remove steering column cover screws (A).
NOTE:
Rotate steering wheel to access steering column cover screws.
4. Release steering column upper cover (1) pawls using a suitable tool and remove.
5. Release steering column lower cover (2) pawl using a suitable tool.

 : Pawl

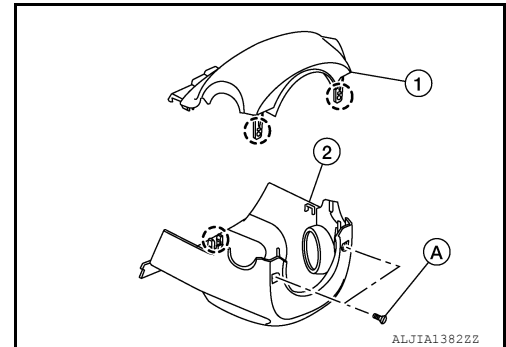

6. Disconnect the harness connector (A) from the ADP steering switch [1 (if equipped)] and remove steering column lower cover.

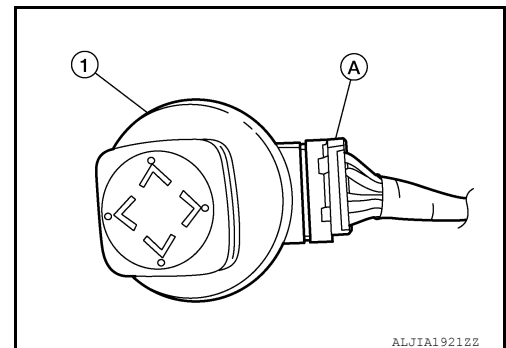

INSTALLATION

Installation is in the reverse order of removal.

CLUSTER LID A

< REMOVAL AND INSTALLATION >

CLUSTER LID A

Removal and Installation

INFOID:000000012545590

REMOVAL

1. Remove cluster lid C finisher (LH). Refer to [IP-16. "CLUSTER LID C FINISHER : Removal and Installation"](#).
2. Remove instrument finisher A. Refer to [IP-15. "INSTRUMENT FINISHER A : Removal and Installation"](#).
3. Disconnect the harness connectors from switches.
4. Release cluster lid A clips and metal clips using a suitable tool and remove.

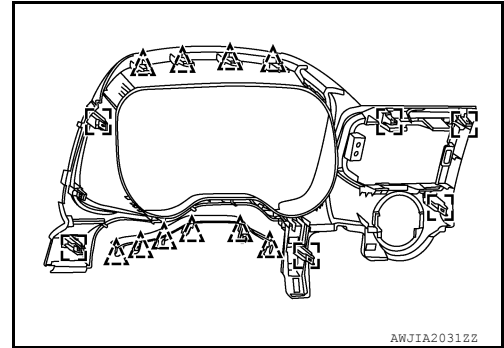
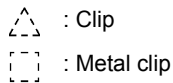

INSTALLATION

Installation is in the reverse order of removal.

A
B
C
D
E
F
G
H
I
IP
K
L
M
N
O
P

CLUSTER LID C

< REMOVAL AND INSTALLATION >

CLUSTER LID C

Removal and Installation

INFOID:000000012545592

REMOVAL

1. Remove cluster lid C lower. Refer to [IP-17, "CLUSTER LID C LOWER : Removal and Installation"](#).
2. Remove screws (A).
3. Release cluster lid C (1) pawls using a suitable tool.

 : Pawl

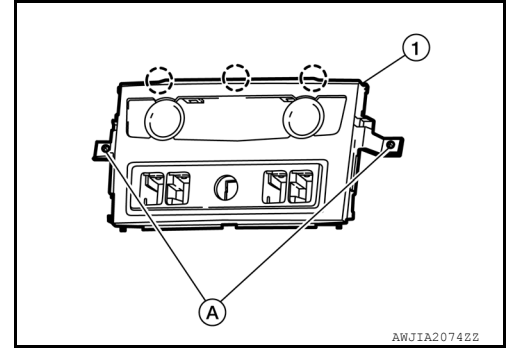

4. Disconnect the harness connectors and remove cluster lid C.

INSTALLATION

Installation is in the reverse order of removal.

GLOVE BOX ASSEMBLY AND HOUSING

< REMOVAL AND INSTALLATION >

GLOVE BOX ASSEMBLY AND HOUSING

Removal and Installation

INFOID:000000012545595

REMOVAL

1. Open the glove box door and remove the glove box upper screws (A).

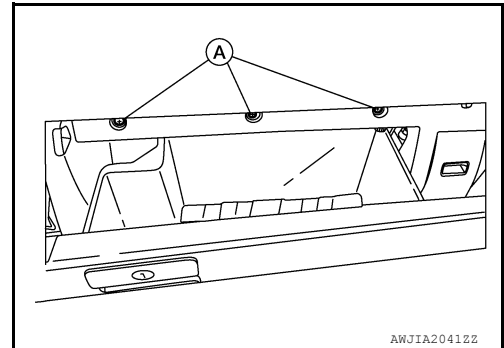

2. Remove the glove box lower screws (A).
3. Release glove box metal clips using a suitable tool.

 : Metal clip

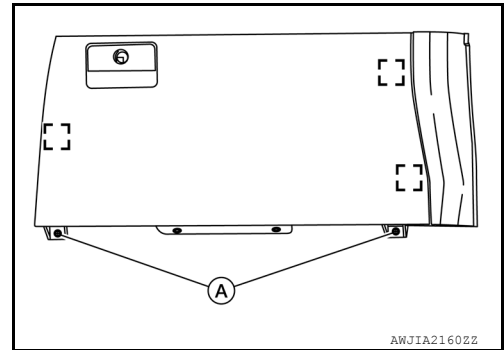

4. Disconnect harness connector and remove the glove box.

INSTALLATION

Installation is in the reverse order of removal.

A

B

C

D

E

F

G

H

I

IP

K

L

M

N

O

P

INSTRUMENT LOWER PANEL LH

< REMOVAL AND INSTALLATION >

INSTRUMENT LOWER PANEL LH

Removal and Installation

INFOID:000000012545596

REMOVAL

1. Remove instrument lower panel LH (1) screws (A).
2. Disconnect in vehicle sensor tube.
3. Release instrument lower panel LH metal clips using a suitable tool, disconnect harness connectors and remove instrument lower panel LH.

 : Metal clip

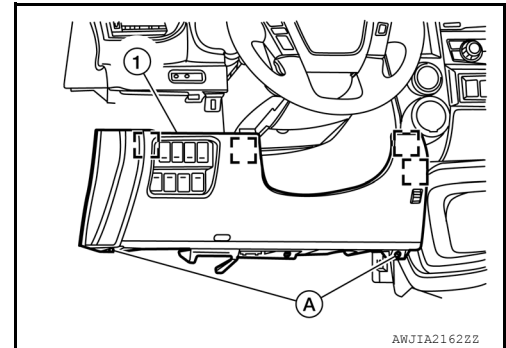

INSTALLATION

Installation is in the reverse order of removal.

CENTER CONSOLE

< REMOVAL AND INSTALLATION >

CENTER CONSOLE

Exploded View

INFOID:000000012545598

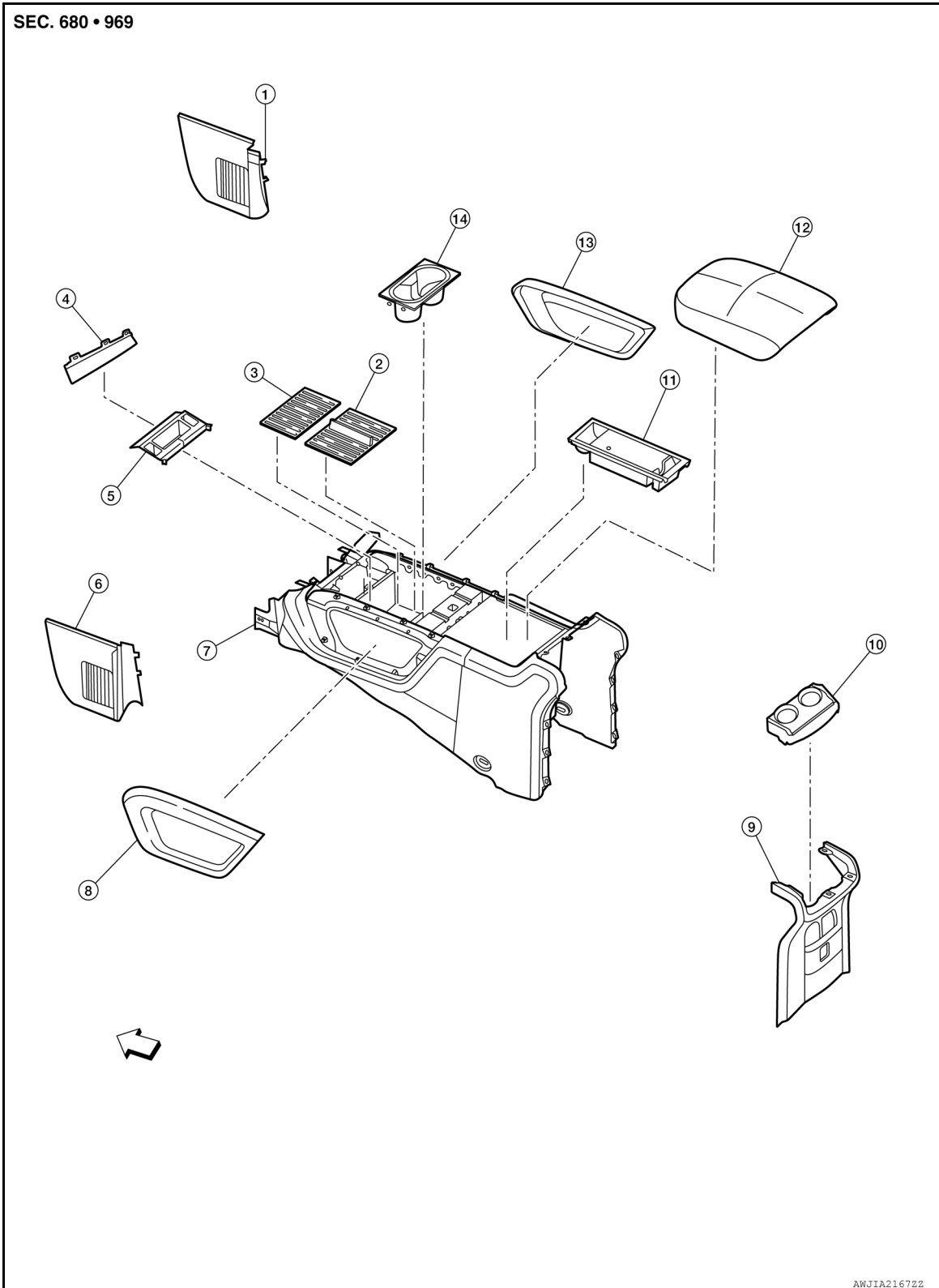

- | | | |
|-------------------------------|----------------------------|---------------------------------|
| 1. Instrument stay cover (RH) | 2. Rubber mat | 3. Console mat |
| 4. Front console cover | 5. Console switch finisher | 6. Instrument stay cover (LH) |
| 7. Center console | 8. Console finisher (LH) | 9. Center console rear finisher |

A
B
C
D
E
F
G
H
I
IP
K
L
M
N
O
P

CENTER CONSOLE

< REMOVAL AND INSTALLATION >

- | | | |
|---------------------------|------------------|-----------------|
| 10. Rear cup holder | 11. Console tray | 12. Console lid |
| 13. Console finisher (RH) | 14. Cup holder | ← Front |

Removal and Installation

INFOID:000000012545599

REMOVAL

1. Remove instrument lower panel LH. Refer to [IP-22, "Removal and Installation"](#).
2. Remove glove box assembly and housing. Refer to [IP-21, "Removal and Installation"](#).
3. Release pawls and remove front console cover.
4. Release clips using suitable tool and position center console rear finisher as necessary to disconnect harness connectors (1).

 : Clip

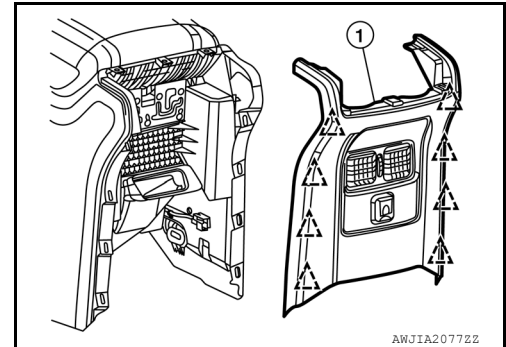

5. Disconnect harness connectors from rear heated seat switch (LH/RH) and from the AC 120V outlet.
6. Remove rear cup holder.
7. Remove instrument stay covers (LH/RH).
8. Remove center console screws (A).
9. Remove center console (1).

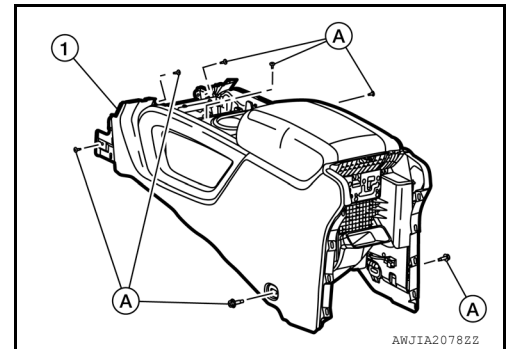

INSTALLATION

Installation is in the reverse order of removal.

CENTER CONSOLE ASSEMBLY

< UNIT DISASSEMBLY AND ASSEMBLY >

UNIT DISASSEMBLY AND ASSEMBLY

CENTER CONSOLE ASSEMBLY

Exploded View

INFOID:0000000012545602

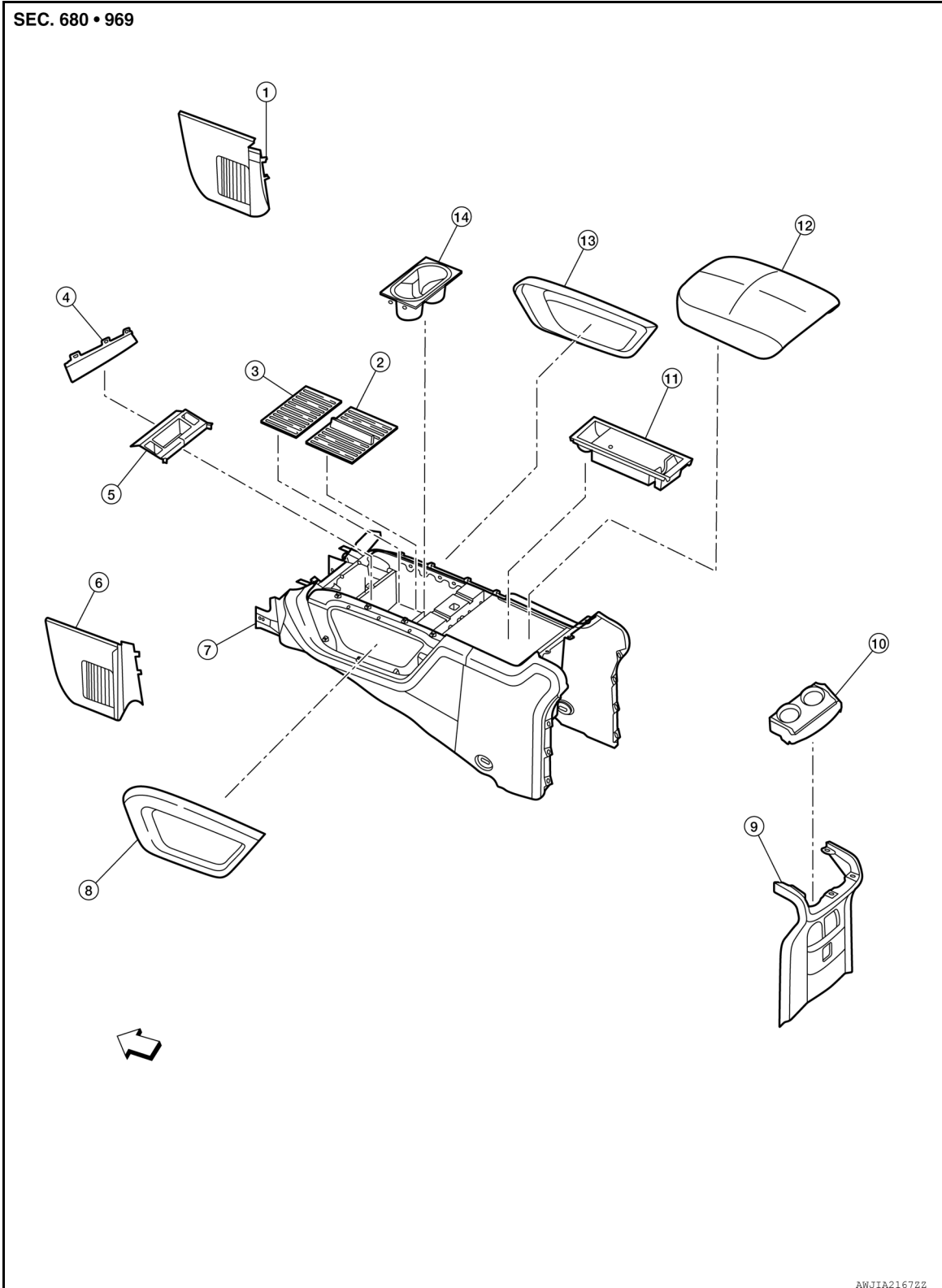

A
B
C
D
E
F
G
H
I
IP
K
L
M
N
O
P

CENTER CONSOLE ASSEMBLY

< UNIT DISASSEMBLY AND ASSEMBLY >

- | | | |
|-------------------------------|----------------------------|---------------------------------|
| 1. Instrument stay cover (RH) | 2. Rubber mat | 3. Console mat |
| 4. Front console cover | 5. Console switch finisher | 6. Instrument stay cover (LH) |
| 7. Center console | 8. Console finisher (LH) | 9. Center console rear finisher |
| 10. Rear cup holder | 11. Console tray | 12. Console lid |
| 13. Console finisher (RH) | 14. Cup holder | ← Front |

Disassembly and Assembly

INFOID:000000012545603

DISASSEMBLY

1. Remove center console. Refer to [IP-24, "Removal and Installation"](#).
2. Remove console lid.
3. Release center console rear finisher and position as necessary to disconnect harness connectors from rear heated seat switch, then remove center console rear finisher.
4. Remove console power socket. Refer to [PWO-11, "Removal and Installation"](#).
5. Remove rubber mat and tray.
6. Remove screw (A) and rear center ventilator duct (2) from the center console (1).
7. Remove console finisher (LH/RH).

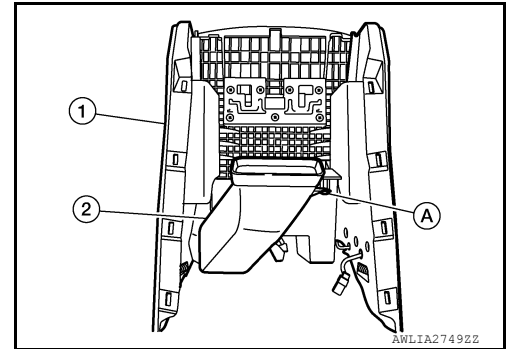

ASSEMBLY

Assembly is in the reverse order of disassembly.